

ACVATIX™

2- and 3-port valves with flanged connections, PN 40

V..F63..



VVF63..
VVF63..K



VXF63..

From the large-stroke valve line

- High-performance valves for medium temperatures of -25...220 °C
- Valve body of cast steel GP240GH
- DN 15...150
- k_{vs} 0.2...315 m³/h
- Flange type 21, flange design B
- Equipable with electro-hydraulic actuators SKD..., SKB..., SKC..

Use

In boiler, district heating and refrigeration plants, cooling towers, heating groups, and in air handling units as control or shutoff valves.

For use in closed or open hydraulic circuits (observe cavitation).

Type summary

	Valves	Actuators				SKD.. ¹⁾	SKB..		SKC..			
		Stroke				20 mm		40 mm				
	PN 40	Positioning force				1000 N		2800 N		2800 N		
		Data sheet				N4561		N4664		N4566		
		Stock no.	DN	k _{vs}	S _v	Δp _s	Δp _{max}	Δp _s	Δp _{max}	Δp _s	Δp _{max}	
[m ³ /h]	[kPa]											
Liquids Preferred flow direction A-AB with liquids for low noise operation and high k _{vs} values with all actuator types	VVF63.15-0.2 ²⁾	S55210-V100	15	0.2	> 50	4000	2000	4000	2000	-	-	
	VVF63.15-0.32 ²⁾	S55210-V101	15	0.32								
	VVF63.15-0.5 ²⁾	S55210-V102	15	0.5								
	VVF63.15-0.8 ^{2) 3)}	S55210-V103	15	0.8								
	VVF63.15-1.25 ^{2) 3)}	S55210-V104	15	1.25								
	VVF63.15-2 ^{2) 3)}	S55210-V105	15	2								
	VVF63.15-3.2 ^{2) 3)}	S55210-V106	15	3.2								
	VVF63.20-6.3	S55210-V107	20	6.3								3500
	VVF63.25-5 ^{2) 3)}	S55210-V108	25	5								2100
	VVF63.25-8 ^{2) 3)}	S55210-V109	25	8								
	VVF63.32-16	S55210-V110	32	16	1200	1100	3200					
	VVF63.40-12.5 ²⁾	S55210-V111	40	12.5	750	650	2000	1800				
	VVF63.40-20 ²⁾	S55210-V112	40	20								
	VVF63.50-31.5 ²⁾	S55210-V113	50	31.5	> 100	450	400	1200	1150			
	VVF63.65-50 ²⁾	S55210-V114	65	50	-	-	-	-	700	650		
VVF63.80-80 ²⁾	S55210-V115	80	80	450	400							
VVF63.100-125 ²⁾	S55210-V116	100	125	300	250							
VVF63.125-200 ²⁾	S55210-V117	125	200	175	160							
VVF63.150-315 ²⁾	S55210-V118	150	315	125	100							
Liquids and Steam Compensated valves are optimized for a single flow direction for liquids and steam. DN 50..150: AB-A	VVF63.50-40K	VVF63.50-40K	50	36	> 100	4000	1500	4000	2000	-	-	
	VVF63.65-63K	VVF63.65-63K	65	63		-	-	-	-	4000	2000	
	VVF63.80-100K	VVF63.80-100K	80	100								
	VVF63.100-150K	VVF63.100-150K	100	150								
	VVF63.125-220K	VVF63.125-220K	125	220	> 50							
	VVF63.150-315K	VVF63.150-315K	150	315								

- 1) Usable up to a max. medium temperature of 150 °C
- 2) Valves with supplemental designation ..F (e.g. VVF63.25-10F) - with special flange can be ordered exclusively for France.
- 3) Valves with supplemental designation ..L (e.g. VVF63.25-10L) - with parabolic plug can be ordered for special applications (low noise).

DN = Nominal size

k_{vs} = Flow nominal value of cold water (5...30 °C) through the fully opened valve (H_{100}) at a differential pressure of 100 kPa (1 bar)

S_v = Rangeability k_{vs} / k_{vr}

Δp_s = Maximum permissible differential pressure at which the motorized valve still closes securely against the pressure

Δp_{max} = Maximum permissible differential pressure across the valve's throughport for the entire positioning range of the motorized valve

	Valves	Actuators				SKD.. ¹⁾	SKB..		SKC..								
		Hub				20 mm		40 mm									
	PN 40	Positioning force				1000 N	2800 N		2800 N								
		Data sheet				N4561	N4664		N4566								
		Stock no.	DN	k_{vs}	S_v	Δp_s	Δp_{max}	Δp_s	Δp_{max}	Δp_s	Δp_{max}						
[m ³ /h]	[kPa]																
Steam ²⁾ Exclusive flow direction AB-A for steam. Also useful for maximum close-off pressure Δp_s and maximum differential pressure in operation (Δp_{max}) with liquids.	VVF63.15-0.2 ²⁾	S55210-V100	15	0.2	> 50	4000	2000	4000	2000	-	-						
	VVF63.15-0.32	S55210-V101	15	0.32													
	VVF63.15-0.5	S55210-V102	15	0.5													
	VVF63.15-0.8	S55210-V103	15	0.8													
	VVF63.15-1.25	S55210-V104	15	1.25													
	VVF63.15-2	S55210-V105	15	2													
	VVF63.15-3.2	S55210-V106	15	3.2													
	VVF63.20-6.3 ³⁾	S55210-V107	20	5													
	VVF63.25-5	S55210-V108	25	5													
	VVF63.25-8	S55210-V109	25	8													
	VVF63.32-16	S55210-V110	32	15								1500					
	VVF63.40-12.5	S55210-V111	40	12.5								1000					
	VVF63.40-20	S55210-V112	40	20													
	VVF63.50-31.5	S55210-V113	50	31.5								600	1900				
	VVF63.65-50	S55210-V114	65	50								-	-	-	-	4000	1000
	VVF63.80-80	S55210-V115	80	80													750
	VVF63.100-125	S55210-V116	100	125													500
	VVF63.125-200	S55210-V117	125	200													300
	VVF63.150-315 ³⁾	S55210-V118	150	280													200

	Valves	Actuators				SKD.. ¹⁾	SKB..	SKC..				
		Stroke				20 mm		40 mm				
	PN 40	Positioning force				1000 N	2800 N	2800 N				
		Data sheet				N4561	N4664	N4566				
		Stock no.	DN	k _{vs}	S _v	Δp _{max}						
[kPa]												
A → AB				AB → A		A → AB		AB → A		A → AB		AB → A
Liquids	VXF63.15-1.6	S55210-V131	15	1.6	> 100	2000	200	2000	200	-	-	
	VXF63.15-2.5	S55210-V132	15	2.5								
	VXF63.15-4	S55210-V133	15	4								
	VXF63.20-6.3	S55210-V134	20	6.3								
	VXF63.25-6.3	S55210-V135	25	6.3								
	VXF63.25-10	S55210-V136	25	10								
	VXF63.32-16	S55210-V137	32	16			1100					
	VXF63.40-16	S55210-V138	40	16			650					
	VXF63.40-25	S55210-V139	40	25								
	VXF63.50-31.5	S55210-V140	50	31.5			400		1150			
	VXF63.65-50	S55210-V141	65	50			-	-	-	-	650	200
	VXF63.80-80	S55210-V142	80	80							400	200
	VXF63.100-125	S55210-V143	100	125							250	150
	VXF63.125-200	S55210-V144	125	200							160	100
	VXF63.150-315	S55210-V145	150	315							100	70



- 1) Usable up to a max. medium temperature of 150 °C
- 2) Operate with opposite flow direction with steam
- 3) Reduced k_{vs} value

Note

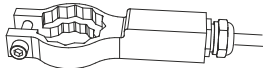

When using a steam heating element with a medium temperature below -5 °C, the stem sealing gland must be replaced. In this case, the sealing gland must be ordered separately.

DN	Stock no.
DN 15...50	4 284 8806 0
DN 65...150	4 679 5629 0

Accessories

Type	Stock no.	Description	Note	
ASZ6.6	S55845-Z108	Steam heating element	Required for medium temperatures < 0 °C	
-	4 284 8806 0	Steam sealing gland	When using valves of the V..F63.. lines DN 15...50 with a stem heating element and a medium temperature below -5 °C, the stem sealing gland must be replaced. With the gland 428488060, the valve can be used with water, water with anti-freeze and brines between -25 °C and 150 °C.	
-	4 679 5629 0	Steam sealing gland	When using valves of the V..F63.. lines DN 65...150 with a stem heating element and a medium temperature below -5 °C, the stem sealing gland must be replaced. With the gland 467956290, the valve can be used with water, water with anti-freeze and brines between -25 °C and 150 °C.	

Spare parts

Type	DN	Stock no.	Notes	
VVF63.. VXF63.. VVF63..K	DN 15...50	74 284 0061 0	Standard version with FEPM O-ring for medium temperatures between -5 °C and 220 °C.	
VVF63.. VXF63.. VVF63..K	DN 65...150	S55846-Z114	Standard version with FEPM O-ring for medium temperatures between -5 °C and 220 °C.	
VVF63.. VXF63..	DN 15...50	4 284 8806 0	When operating with medium temperatures below -5 °C. With the gland 428488060, the valve can be used with water, water with anti-freeze and brines between -25 °C and 150 °C.	
VVF63.. VXF63..	DN 65...150	4 679 5629 0	When operating with medium temperatures below -5 °C. With the gland 467956290, the valve can be used with water, water with anti-freeze and brines between -25 °C and 150 °C.	

Equipment combinations

Type	Stock no.	Stroke	Positioning force	Operating voltage	Positioning signal	Spring return time	Positioning time	LED	Manual adjuster	Auxiliary functions
SKD32.21	SKD32.21	20 mm	1000 N	AC 230 V	3-position	8 s	Opening: 30 s Closing: 10 s	-	Turn, position is maintained	1), 2),
SKD32.50	SKD32.50					-	120 s			
SKD32.51	SKD32.51					8 s				
SKD60	SKD60	20 mm	1000 N	AC 24 V	0...10 V 4...20 mA 0...1000 Ω	-	Opening: 30 s Closing: 10 s	x	Turn, position is maintained	3)
SKD62 SKD62U	SKD62 SKD62U					15 s				
SKD62UA	SKD62UA									

Type	Stock no.	Stroke	Positioning force	Operating voltage	Positioning signal	Spring return time	Positioning time	LED	Manual adjuster	Auxiliary functions			
SKD82.50 SKD82.50U	SKD82.50 SKD82.50U				3-position	-	120 s	-		1), 2),			
SKD82.51 SKD82.51U	SKD82.51 SKD82.51U					8 s							
SKB32.50 SKB32.51	SKB32.50 SKB32.51	20 mm	2800 N	AC 230 V	3-position	-	120 s	-	Turn, position is maintained	1), 2),			
SKB60 SKB62 SKB62U	SKB60 SKB62 SKB62U					AC 24 V					0...10 V 4...20 mA 0...1000 Ω	-	Opening: 120 s Closing: 10 s
SKB62UA	SKB62UA					10 s	4)						
SKB82.50 SKB82.50U	SKB82.50 SKB82.50U			3-position	-	120 s	-	1), 2),					
SKB82.51 SKB82.51U	SKB82.51 SKB82.51U									10 s			
SKC32.60 SKC32.61	SKC32.60 SKC32.61			40 mm	2800 N	AC 230 V	3-position	-		120 s	-	Turn, position is maintained	1), 2),
SKC60 SKC62 SKC62U	SKC60 SKC62 SKC62U							AC 24 V					
SKC62UA	SKC62UA							20 s		4)			
SKC82.60 SKC82.60U	SKC82.60 SKC82.60U	3-position	-			120 s	-	1), 2),					
SKC82.61 SKC82.61U	SKC82.61 SKC82.61U								18 s				

- 1) Auxiliary switch (optional)
- 2) Potentiometer (optional)
- 3) Position feedback, forced control, selection of valve characteristic
- 4) Plus sequence control, stroke limitation, selection of acting direction

Ordering (Example)

Type	Stock no.	Description
VXF63.32-16	S55210-V137	3-port valve with flange, PN 40, DN32

Delivery

Valves, actuators, and accessories are packed and delivered separately.

Note

Counter-flanges, bolts, and gaskets must be provided on site.

Product documentation

Title	Content	Document ID
Mounting instructions Valves VVF.. VXF..	Mounting instructions: DN 15...150	M4030 74 319 0749 0
Valves VVF..., VXF..., VVG41..., VXG41..., VVI41..., VXI41..	Basic documentation: Contains background information and general technical basics of valves	P4030

Technical design

The illustrations below show the basic design of the valves. Constructional features, such as the shape of plugs, may differ.

2-port valves

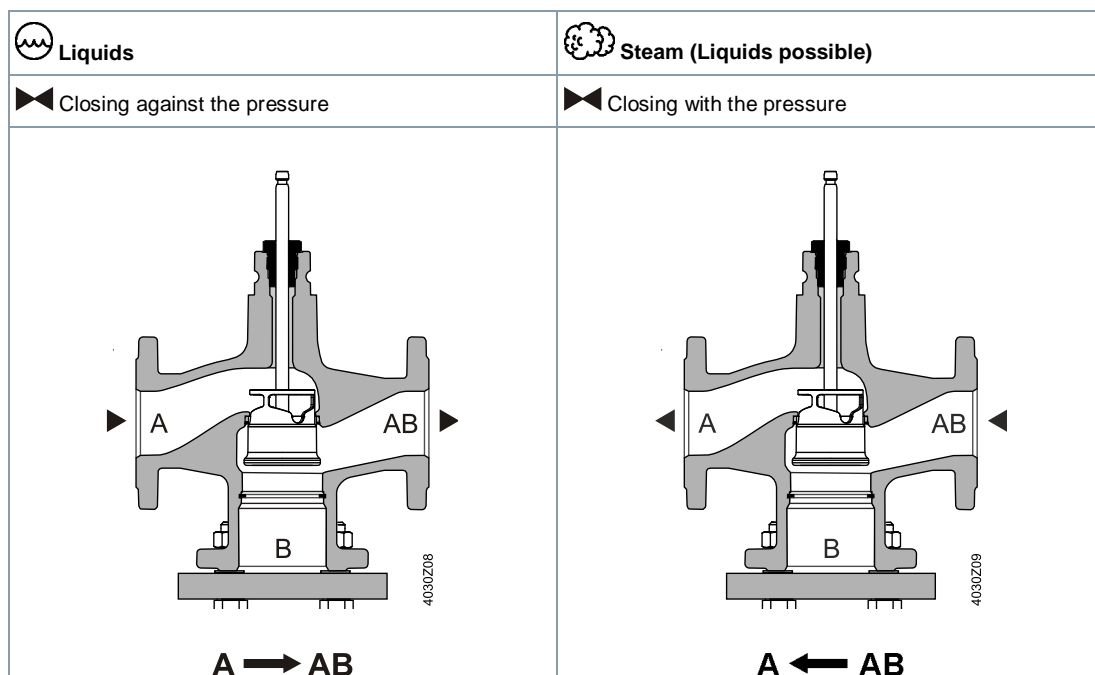

2-port valves **pressure-compensated**

The VVF63..K valves use a pressure-compensated plug. This enables the same type of actuators to be used for the control of volumetric flow at higher differential pressures.



DN 50...150 Liquids and steam

Closing with the pressure

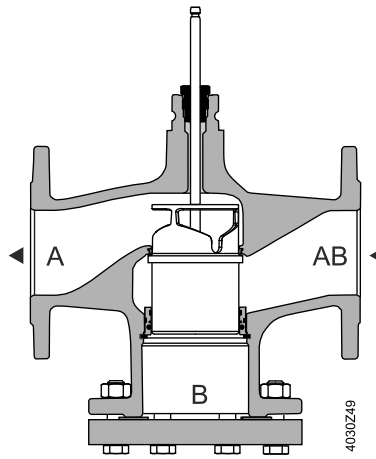

A ← AB

Note

2-port valves do not become 3-port valves by removing the blank flange!

3-port valves



Liquids

Mixing valve (preferred use)

Diverting valve

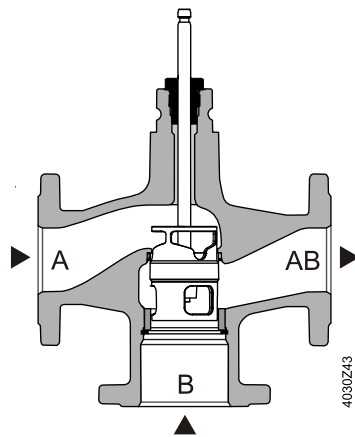

A → AB
B

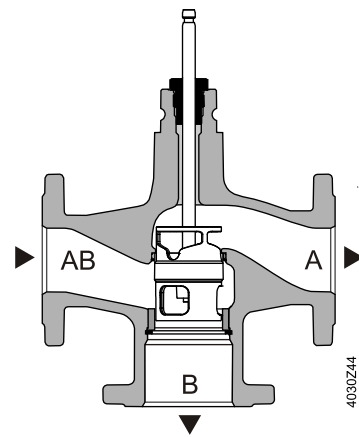

AB → A
B

Sizing

Flow chart

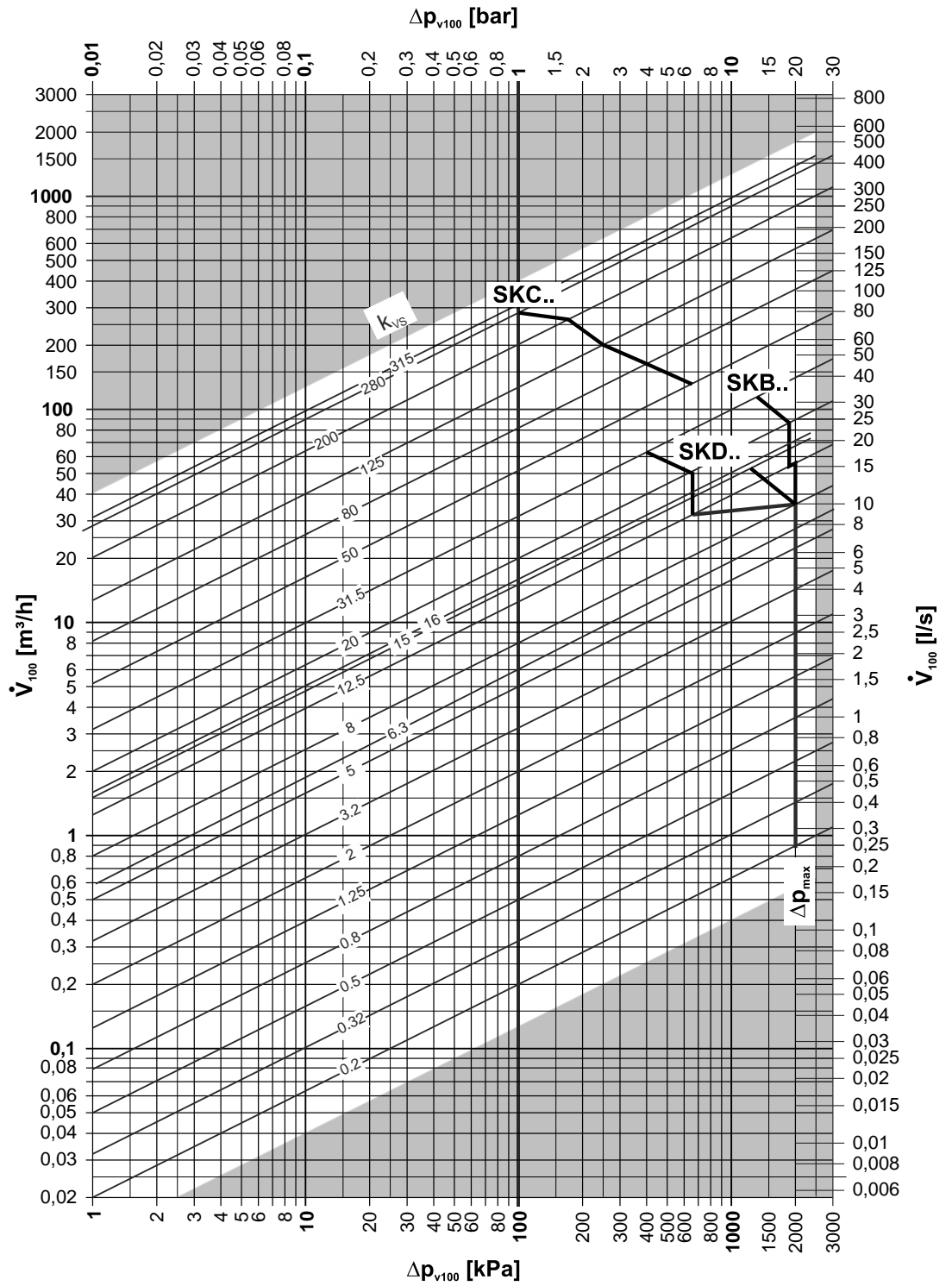

Δp_{max} values apply for the mixing function; Δp_{max} for the diverting function. See Type summary [► 2].

Valve characteristics

2-port valves

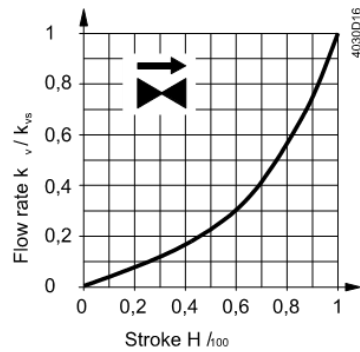

0...30 %: Linear
 30...100 %: Equal percentage
 $n_{gl} = 3$ to VDI / VDE 2173

For high k_{vs} values, the valve characteristic is optimized for maximum volumetric flow k_{v100} .

For product lines:
 VVF63.125-220K
 VVF63.150-315K

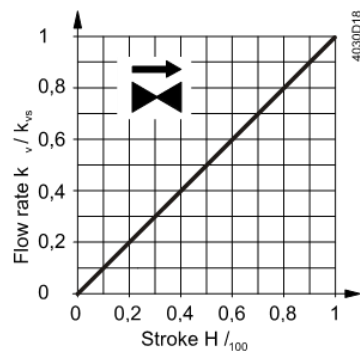

0...100 %: Linear

3-port valves

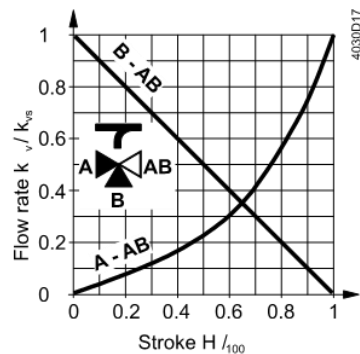

Throughport A-AB

0...30 %: Linear
 30...100 %: Equal percentage
 $n_{gl} = 3$ to VDI / VDE 2173

For high k_{vs} values, the valve characteristic is optimized for maximum volumetric k_{v100} .

Bypass B-AB

0...100 %: Linear

Port AB = constant volumetric flow

Port A = variable volumetric flow

Port B = Bypass (variable volumetric flow)

Mixing: Volumetric flow from port A and port B to port AB

Diverting: Volumetric flow from port AB to port A and port B

Operating pressure and medium temperature

Liquids
with V..F63..

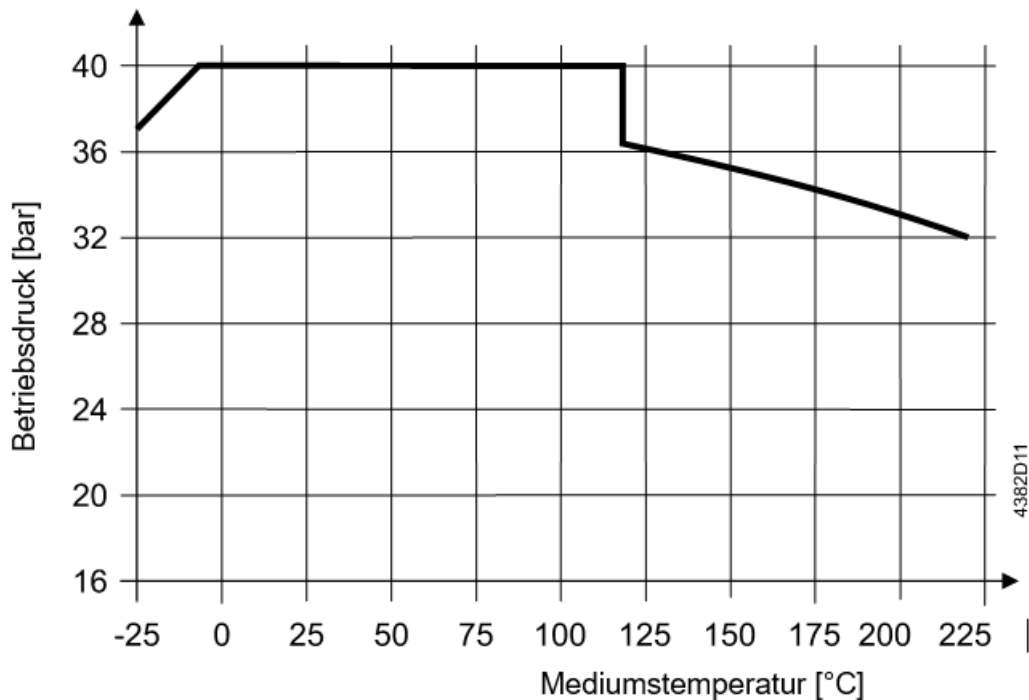

Operating pressure and operating temperatures according to ISO 7005, EN 1092, DIN 4747 and EN 12284

Note: All relevant local directives must be observed

Saturated steam
Superheated steam
with V..F63..

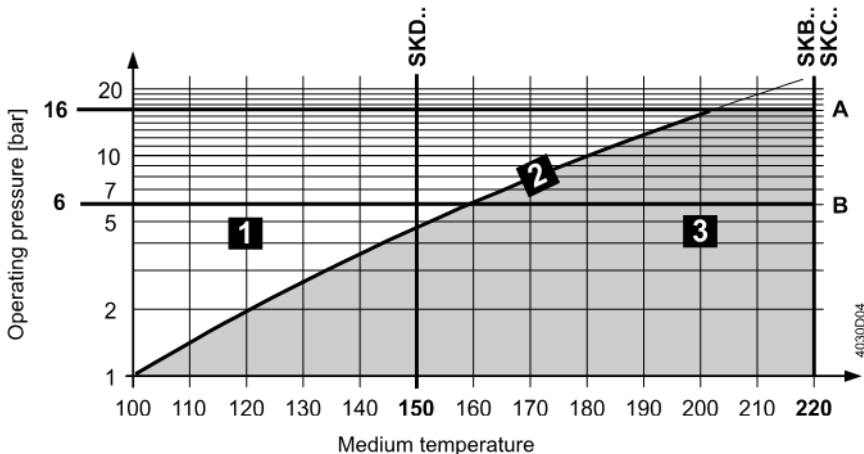

1	Water	-
2	Wet steam	To be avoided
3	Saturated steam Superheated steam	Permissible operating range
A	Subcritical pressure ratio	
B	Supercritical pressure ratio	

Medium compatibility and temperature ranges

	Temperature range		VVF63..	VXF63..	VVF63..K	
	T _{min} [°C]	T _{max} [°C]				
Cold water	1	25	x	x	x	-
Low-temperature hot water	1	130	x	x	x	-
High-temperature hot water	130	150	x	x	x	-
	150	180	x	x	x	-
	180	220	x	x	x	-
Water with anti-freeze	-25	130	x	x	- ¹⁾	V..F63: For medium temperatures below -5 °C, the steam sealing gland must be replaced (DN15..50: 4 284 8806 0) (DN65..150: 4 679 5629 0).
	-10	130	x	x	- ¹⁾	
	-5	130	x	x	x	
	130	150	x	x	x	
Cooling water	1	25	x	x	x	Open circuits
Brines	-25	130	x	x	- ¹⁾	V..F63: For medium temperatures below -5 °C, the steam sealing gland must be replaced (DN15..50: 4 284 8806 0) (DN65..150: 4 679 5629 0).
	-10	130	x	x	- ¹⁾	
	-5	130	x	x	x	
	130	150	x	x	x	
Saturated steam	100	150	x	-	x	Min. dryness at inlet: 0.98
	150	200	x	-	x	
	200	220	x	-	x	
Superheated steam	120	150	x	-	x	-
	150	220	x	-	x	-
Heat transfer oils	20	220	x	x	x	On the basis of mineral oil, thermal oil
Super-clean water (demineralized and deionized water)	1	150	-	-	-	-
Demineralized water according to VDI2035 / SWKI_BT102-01	1	130	x	x	x	

¹⁾ VVF63..K valves cannot be used with media below -5 °C due to the compensation sealing material.

Fields of use

Fields of use		Type	
		VVF63..	VXF63..
Generation	Boiler plants	x	x
	District heating plants	x	-
	Refrigeration plants	x	x
	Cooling towers ²⁾	x	x
Distribution	Heating groups	x	x
	Air handling units	x	x

²⁾ Open circuits

Notes

Engineering

Mounting location

Preferably mount the valves at the return, as the temperature is lower there and the stain on the steam sealing gland is lower.

Dirt trap

Mount a dirt filter or dirt trap before the valve to ensure proper functioning, and a long service life of the valves.

Remove dirt, welding beads, etc. from the valves and pipes.

Cavitation

Cavitation can be avoided by limiting the pressure differential across the valve depending on the medium temperature and the pre-pressure.

Mounting

Mounting position

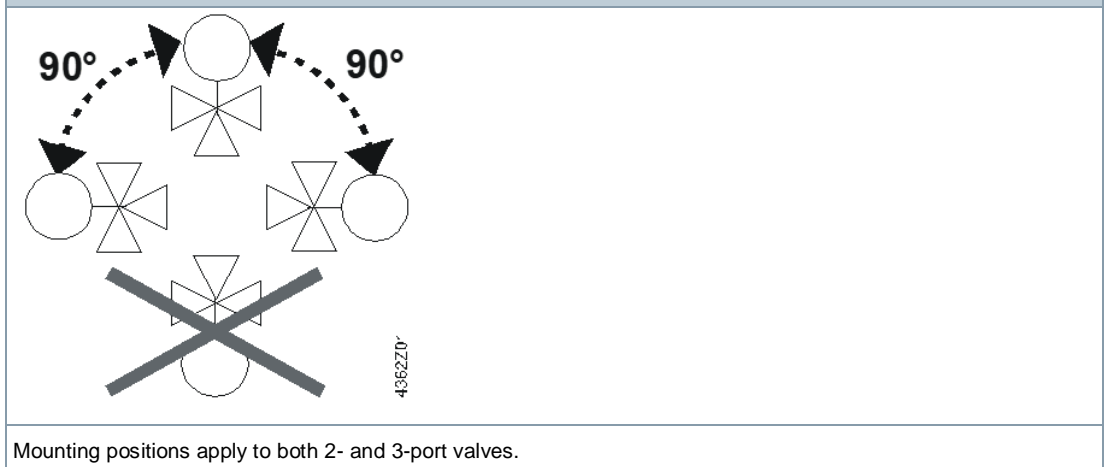

Commissioning



The valve may be put into operation only if actuator and valve are correctly assembled.

Note

Ensure that the actuator stem and valve stem are rigidly connected in all positions.

Function check

Valve	Throughport A->AB or AB->A	Bypass B->AB
Valve stem extends	Closes	Opens
Valve steam retracts	Opens	Closes

Maintenance

The valves are maintenance-free.

CAUTION



When servicing valves or actuators:

- Deactivate the pump and turn off the power supply
- Close the shutoff valves
- Fully reduce the pressure in the piping system and allow the pipes to completely cool down

If necessary, disconnect the electrical wires.

Disposal

Do not dispose of the valve as part of domestic waste.

- Special treatment for individual components may be required by law or make ecological sense.
- Comply with all local and currently applicable laws and regulations.

Warranty

Application-related technical data are guaranteed only when the valves are used in combination with the Siemens actuators listed under "Type summary" and "Equipment combinations". When used with actuators of third-party manufacturers, any warranty by Siemens becomes void.

Functional data			
PN class		PN 40	
Connection		Flange	
Operating pressures		See "Operating pressure", see page 11	
Valve characteristic ¹⁾		See "Valve characteristics", page 10	
Leakage rate	Throughport	DN 15...150	0...0.01 % of k_{vs} value (Class IV)
	Bypass		0.5...2 % of k_{vs} value with SKD..., SKB..., SKC..
Permissible media		See "Medium compatibility and temperature ranges", page 12 Heat transfer oils	
Medium temperature		-25...220 °C ²⁾	
		VVF63..K	-5...220 °C
Rangeability	DN15 k_{vs} 0.2...1.25	>50	
	DN15 k_{vs} 2 ... DN150	>100	
Nominal stroke	Up to DN 50	20 mm	
	From DN 65	40 mm	

Materials		
Valve body		Cast steel GP240GH
Blank flange	VVF..	P265GH
Valve stem, seat, plug		Stainless steel
Steam sealing gland		Stainless steel
	DN 15...150	FEPM (silicone free)
Compensation sealing		Stainless steel
	DN 15...150	FEPM (silicone free)

Standards and directives		
Pressure Equipment Directive Pressure accessories		PED 2014/68/EU Scope: Article 1, section 1 Definition: Article 2, section 5
Liquid group 2	DN 15...40	Without CE-marking, as per article 4, section 3 (sound engineering practice) ³⁾
	DN 50...80	Category I, Module A, with CE-marking, as per article 14, section 2
	DN 100...150	Category II, Module A2, with CE-marking, as per article 14, section 2
		Notified body number 0036
EU conformity (CE)	DN 50...150	A5W00006523 ⁴⁾
PN class		ISO 7268

Standards and directives		
Operating pressure		ISO 7005, EN1092, DIN 4747, EN 12284
Flanges		ISO 7005
Length of flanged valves		DIN EN 558-1, line 1
Valve characteristic		VDI 2173
Leakage rate	Throughport, Bypass	according to EN 60534-4 / EN 1349
Water treatment		VDI 2035

Environmental conditions		
Storage		IEC 60721-3-1
	Class	1K3
	Temperature	-15...55 °C
	Rel. humidity	5...95 % r.h.
Transportation		IEC 60721-3-2
	Class	2K3, 2M2
	Temperature	-30...65 °C
	Rel. humidity	< 95 % r.h.
Operation		IEC 60721-3-3
	Class	3K5, 3Z11
	Temperature	-15...55 °C
	Rel. humidity	5...95 % r.h.

Environmental compatibility
The product environmental declarations A5W00049179 ⁴⁾ , A5W00049180 ⁴⁾ und A5W00049181 ⁴⁾ contain data on environmentally compatible product design and assessments (RoHS compliance, materials composition, packaging, environmental benefit, disposal).

Dimensions / Weight	
Dimensions	See Dimensions [► 17]
Weight	

- 1) For certain valve lines and high k_{vs} values, the valve characteristic is optimized for maximum volumetric flow k_{V100} .
- 2) With SKD...: Usable up to a max. medium temperature of 150 °C
For medium temperatures < -5 °C, the stem sealing gland must be replaced, see page 4 [► 5]
- 3) Valves where $PS \times DN < 1000$ do not require special testing and cannot carry the CE-marking
- 4) The documents can be downloaded from <http://www.siemens.com/bt/download>

VVF63..

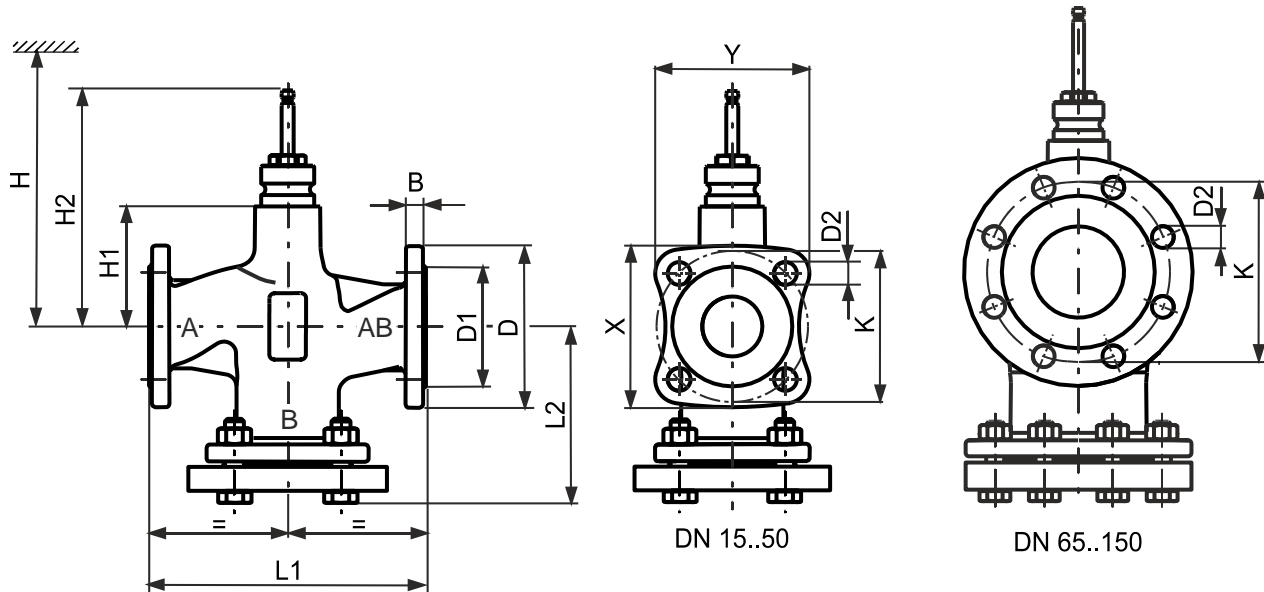

Type	DN	kg	B	Ø D	Ø D1	Ø D2	L1	L2	X	Y	Ø K	H1	H2	H		
														SKD	SKB	SKC
VVF63..	15	5.3	14	95	46	14 (4x)	130	87.5	79	76	65	63	159.5	563	638	-
	20	6.5	16	105	56	14 (4x)	150	99.5	86.6	83	75	63	144.4	563	638	-
	25	7.5	15	115	65	14 (4x)	160	104.5	94.4	90.1	85	63	159.5	563	638	-
	32	10.6	17	140	76	19 (4x)	180	119	115.6	110.7	100	60	156.5	560	635	-
	40	12.3	16	150	84	19 (4x)	200	129	123.2	117.8	110	60	156.5	560	635	-
	50	13.4	16	165	99	19 (4x)	230	146	135.2	128.4	125	100	196.5	600	675	-
	65	29.1	17	185	118	19 (8x)	290	178	-	-	145	115	231.5	-	-	690
	80	36.9	17	200	132	19 (8x)	310	190	-	-	160	115	231.5	-	-	690
	100	49.8	17	235	156	23 (8x)	350	212.5	-	-	190	146	262.5	-	-	721
	125	73.0	17	270	184	28 (8x)	400	242	-	-	220	159	275.5	-	-	734
	150	102.4	17	297	211	28 (8x)	480	284	-	-	250	186.5	303	-	-	762
VVF63..K	50	17.4	16	165	99	19 (4x)	230	146	135.2	128.4	125	100	196.5	600	675	-
	65	29.2	17	185	118	19 (8x)	290	178	-	-	145	115	231.5	-	-	690
	80	37.1	17	200	132	19 (8x)	310	190	-	-	160	115	231.5	-	-	690
	100	50.2	17	235	156	23 (8x)	350	212.5	-	-	190	146	262.5	-	-	721
	125	73.7	17	270	184	28 (8x)	400	242	-	-	220	159	275.5	-	-	734
	150	103.9	17	297	211	28 (8x)	480	284	-	-	250	186.5	303	-	-	762

VXF63..

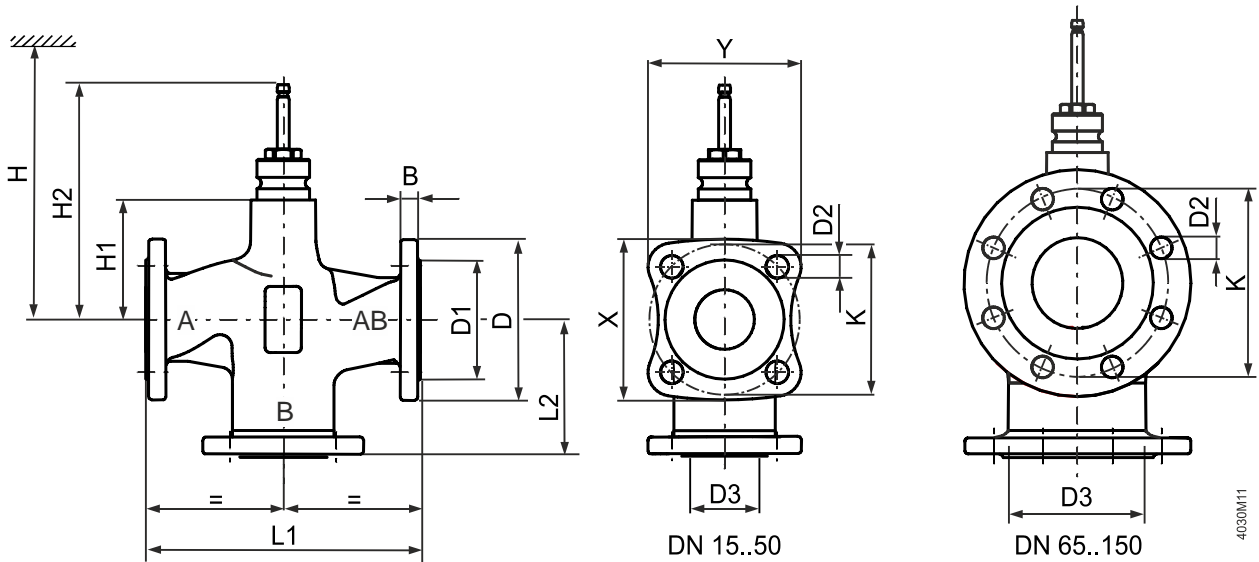

Type	DN	kg	B	Ø D	Ø D1	Ø D2	L1	L2	X	Y	Ø K	H1	H2	H		
														SKD	SKB	SKC
VXF63..	15	4.3	14	95	46	14 (4x)	130	65	79	76	65	63	159.5	563	638	-
	20	5.2	16	105	56	14 (4x)	150	75	86.6	83	75	63	159.5	563	638	-
	25	6.0	15	115	65	14 (4x)	160	80	94.4	90.1	85	63	159.5	563	638	-
	32	8.0	17	140	76	19 (4x)	180	90	115.6	110.7	100	60	156.5	560	635	-
	40	9.4	16	150	84	19 (4x)	200	100	123.2	117.8	110	60	156.5	560	635	-
	50	13.5	16	165	99	19 (4x)	230	115	135.2	128.4	125	100	196.5	600	675	-
	65	23.5	17	185	118	19 (8x)	290	145	-	-	145	115	231.5	-	-	690
	80	30.1	17	200	132	19 (8x)	310	155	-	-	160	115	231.5	-	-	690
	100	39.8	17	235	156	23 (8x)	350	175	-	-	190	146	262.5	-	-	721
	125	58.4	17	270	184	28 (8x)	400	200	-	-	220	159	275.5	-	-	734
150	84.0	17	297	211	28 (8x)	480	240	-	-	250	186.5	303	-	-	762	

1) Bypass port clear inner width

Revision numbers

Type	Valid from rev. no.	Type	Valid from rev. no.	Type	Valid from rev. no.
VVF63.15-0.2	...B	VVF63.50-40K	...B	VXF63.15-1.6	...B
VVF63.15-0.32	...B	VVF63.65-63K	...B	VXF63.15-2.5	...B
VVF63.15-0.5	...B	VVF63.80-100K	...B	VXF63.15-4	...B
VVF63.15-0.8	...B	VVF63.100-150K	...B	VXF63.20-6.3	...B
VVF63.15-1.25	...B	VVF63.125-220K	...B	VXF63.25-6.3	...B
VVF63.15-2	...B	VVF63.150-315K	...B	VXF63.25-10	...B
VVF63.15-3.2	...B			VXF63.32-16	...B
VVF63.20-6.3	...B			VXF63.40-16	...B
VVF63.25-5	...B			VXF63.40-25	...B
VVF63.25-8	...B			VXF63.50-31.5	...B
VVF63.32-16	...B			VXF63.65-50	...B
VVF63.40-12.5	...B			VXF63.80-80	...B
VVF63.40-20	...B			VXF63.100-125	...B
VVF63.50-31.5	...B			VXF63.125-200	...B
VVF63.65-50	...B			VXF63.150-315	...B
VVF63.80-80	...B				
VVF63.100-125	...B				
VVF63.125-200	...B				
VVF63.150-315	...B				