

ACVATIX™

PICV PN16/PN25 with flanged connections

PN16: VPF43../VPF44..

PN25: VPF53../VPF54..



VPF44../VPF54..



VPF43../VPF53..

Pressure Independent Control Valves (PICV)

- With integrated pressure differential controller
- Valve body made of gray cast iron GJL-250 (PN16) and nodular cast iron GJL-400 (PN25)
- Available in the range from DN50 to 200
- Volumetric flow 15 to 280 m³/h nominal, with presetting
- Equipped with pressure test points P/T
- Can be equipped with SAX..P., SAV..P. or SQV..P. electromotoric actuators

Use

- For use in heating, ventilation and air conditioning systems, district heating, as a control valve
- For closed circuits

Type summary

	Product number	Stock number	DN	H ₁₀₀ [mm]	V _{min} [m ³ /h]	V ₁₀₀ [m ³ /h]	ΔP _{min} [kPa]
Standard flow rate	VPF44.50F15	S55266-V174	50	20	3.7	14.3	on page 9
	VPF54.50F15	S55266-V152					
	VPF44.65F25	S55266-V176	65		4.5	24.4	
	VPF54.65F25	S55266-V154					
	VPF44.80F35	S55266-V178	80		6.8	35.7	
	VPF54.80F35	S55266-V156					
	VPF44.100F70	S55266-V142	100	40	12.2	69.6	
	VPF54.100F70	S55266-V158					
	VPF43.125F110	S55266-V108	125		18.5	110	
	VPF53.125F110	S55266-V120					
	VPF43.150F160	S55266-V110	150	43	25.6	148	
	VPF53.150F160	S55266-V122					
	VPF43.200F210	S55266-V148	200		95	210	
VPF53.200F210	S55266-V150						
High flow rate	VPF44.50F25	S55266-V175	50	20	5.7	24.6	on page 10
	VPF54.50F25	S55266-V153					
	VPF44.65F35	S55266-V177	65		6.4	37.7	
	VPF54.65F35	S55266-V155					
	VPF44.80F45	S55266-V179	80		8.5	49.9	
	VPF54.80F45	S55266-V157					
	VPF44.100F90	S55266-V143	100	40	14.8	90.9	
	VPF54.100F90	S55266-V159					
	VPF43.125F135	S55266-V109	125		23	135	
	VPF53.125F135	S55266-V121					
	VPF43.150F200	S55266-V111	150	43	32	195	
	VPF53.150F200	S55266-V123					
	VPF43.200F280	S55266-V149	200		130	280	
VPF53.200F280	S55266-V151						

Note:

DN = nominal size

H₁₀₀ = nominal stroke

V₁₀₀ = volumetric flow through fully open valve (H₁₀₀)

V_{min} = smallest pre-settable volumetric flow through fully open valve (H₁₀₀)

ΔP_{min} = minimum differential pressure required across the valve's control path, so that the differential pressure regulator works reliably

Ordering

PICV valve, actuator must be ordered separately.

When ordering please specify the quantity, product name and type code.

Example:

Product number	Stock number	Designation
VPF44.65F25	S55266-V176	PICV PN16 with flanged connections

Delivery

- PICVs, actuators and accessories are packed and supplied separately.
- The valves are supplied without counter-flanges and without flange gaskets.

Equipment combinations

Valves				Actuators					
				SAX..P..		SQV..P..		SAV..P..	
		DN	H ₁₀₀ [mm]	Δp _{max} [kPa]	Δp _s [kPa]	Δp _{max} [kPa]	Δp _s [kPa]	Δp _{max} [kPa]	Δp _s [kPa]
Standard flow rate	VPF44.50F15 VPF54.50F15	50	20	600	700	600	700	-	-
	VPF44.65F25 VPF54.65F25	65							
	VPF44.80F35 VPF54.80F35	80							
	VPF44.100F70 VPF54.100F70	100	40	-	-	600	600	600	700
	VPF43.125F110 VPF53.125F110	125							
	VPF43.150F160 VPF53.150F160	150	43	-	-	600	600	600	600
	VPF43.200F210 VPF53.200F210	200							
High flow rate	VPF44.50F25 VPF54.50F25	50	20	600	700	600	700	-	-
	VPF44.65F35 VPF54.65F35	65							
	VPF44.80F45 VPF54.80F45	80							
	VPF44.100F90 VPF54.100F90	100	40	-	-	600	600	600	700
	VPF43.125F135 VPF53.125F135	125							
	VPF43.150F200 VPF53.150F200	150	43	-	-	600	600	600	600
	VPF43.200F280 VPF53.200F280	200							

Note:

H₁₀₀ = nominal stroke

Δp_{max} = maximum permissible differential pressure across valve's control path, valid for the entire actuating range of the motorized valve

Δp_s = maximum permissible differential pressure at which the motorized valve will close securely against the pressure (close off pressure)

Actuator overview

Type	Stock number	Stroke	Positioning force	Operating voltage	Positioning signal	Spring return time	Spring return direction	Positioning time	LED	Manual adjuster	Extra functions
SAX31P03	S55150-A118	20 mm	500 N	AC 230 V	3-position	-	-	30 s	-	Push and fix	1)
SAX61P03	S55150-A114			AC/DC 24 V	DC 0...10 V DC 4...20 mA 0...1000 Ω	-	-	30 s	√		2), 3)
SAX81P03	S55150-A116				3-position	-	-	-	-		1)
SQV91P30	S55150-A130	20 mm	1100 N	AC/DC 24 V	3-position	30 s	Pull to open or push to close ⁵⁾	< 120 s ⁵⁾	√	Turn and fix	1), 6)
SQV91P40	S55150-A131	40 mm		AC 230 V ⁴⁾	DC 0...10 V DC 4...20 mA						
SAV31P00	S55150-A121	40 mm	1100 N	AC 230 V	3-position	-	-	120 s	-	Push and fix	1)
SAV61P00	S55150-A119	-	-	AC/DC 24 V	DC 0...10 V DC 4...20 mA 0...1000 Ω	-	-		√	-	2), 3)
SAV81P00	S55150-A120				3-position	-	-		-	-	1)
SAV61P00/MO ⁷⁾	S55150-A144	40 mm	1100 N	AC/DC 24 V	Modbus RTU	-	-	120 s	√	Push and fix	6)
SAX61P03/MO ⁸⁾	S55150-A143	20 mm	500 N	AC/DC 24 V	Modbus RTU	-	-	30 s	√	Push and fix	3) 6)

- 1) Optional accessories: Auxiliary switch, potentiometer
- 2) Position feedback, forced control, change of flow characteristic
- 3) Optional accessories: Auxiliary switch, sequence control, acting direction
- 4) Voltage adapter required, order separately
- 5) Selectable
- 6) Position feedback, forced control
- 7) UL certified
- 8) UL certified and CE conform

Accessories

Product numbers	Order number	Designation	
ALE10	ALE10		<p>Electronic manometer excluding measuring lines and measuring tips. Measuring range 0 .. 700 kPa. A differential pressure of more than 1000 kPa will destroy the pressure sensor.</p> <p>For measuring the differential pressure between P₁ and P₂/P₃ of the PICVs (refer to diagram under "Functional principle").</p> <p>Functions of the manometer:</p> <ul style="list-style-type: none"> • Start/stop • Automatic zero position • Backlit display • Display: Out → outside the measuring range • Holding function
ALE11	ALE11		<p>Measuring lines and straight measuring tips for use with Siemens PICVs. Equipped with G 1/8" connection with 2 x 40 mm needles.</p>
ALP45	ALP45		<p>Spare nipples P/T port (set of 2). Set contains 1 piece each with a red and blue ribbon. Port: External threads G 1/8 " to ISO 228 Connection to valve body: G 1/4 " to ISO 228, including O-ring Length: 40 mm</p>
ALP46 (only for p ₁ , p ₃)	S55264-V115		<p>Blanking plugs for P/T ports Connection to valve body: G 1/4" to ISO 228, inclusive O-ring</p>
ALP47 (only for p ₁ , p ₃)	S55264-V116		<p>Drain ball valve inclusive O-ring Port: External threads G 1/2" to ISO 228 Connection to valve body: G 1/4" to ISO 228, inclusive O-ring Length: 48 mm</p>
ALP48 (only for p ₁ , p ₃)	S55264-V117		<p>Combined P/T port and drain ball valve with blue ribbon Port: External threads G 1/8" to ISO 228 Connection to valve body: G 1/4" to ISO 228, inclusive O-ring Length: 80 mm</p>
ALP49	S55264-V118		<p>Long P/T ports (set of 2 pieces) Set contains 1 piece each with a red and blue ribbon. Port: External threads G 1/8" to ISO 228 Connection to valve body: G 1/4" to ISO 228, inclusive O-ring Length: 120 mm</p>

VPF43../VPF53..

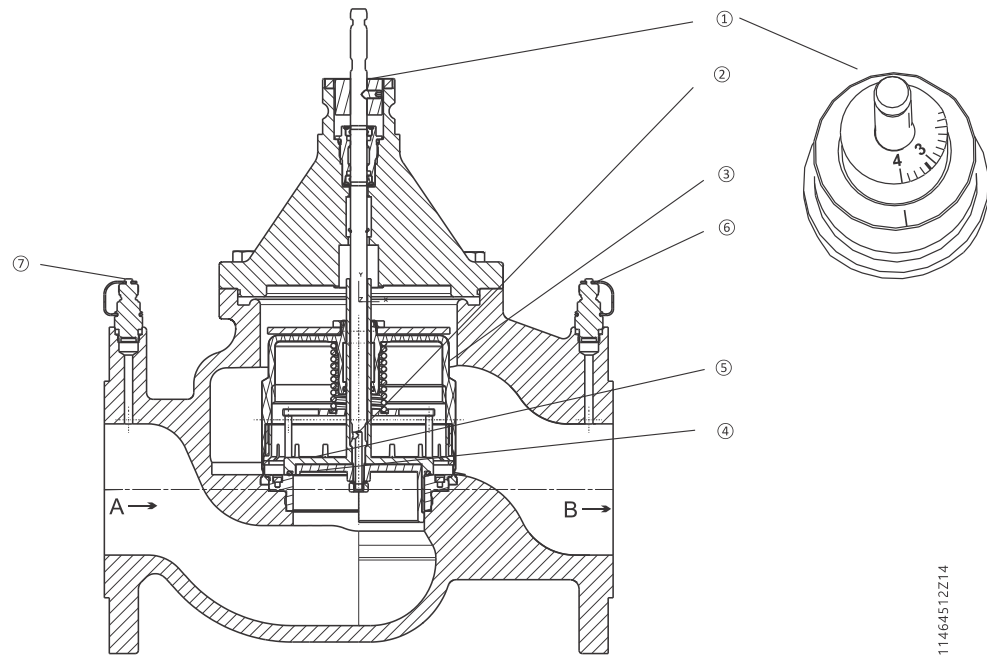

A6V11464512Z14

1	Ring with dial for presetting
2	Aperture for the differential pressure controller is linked with outlet port B
3	Differential pressure controller
4	Plug with variable presetting opening
5	Control valve
6	Pressure test point (P/T) at outlet port B, blue ribbon, p_3
7	Pressure test point (P/T) at inlet port A, red ribbon, p_1
A	Inlet port A
B	Outlet port B

VPF44../VPF54..

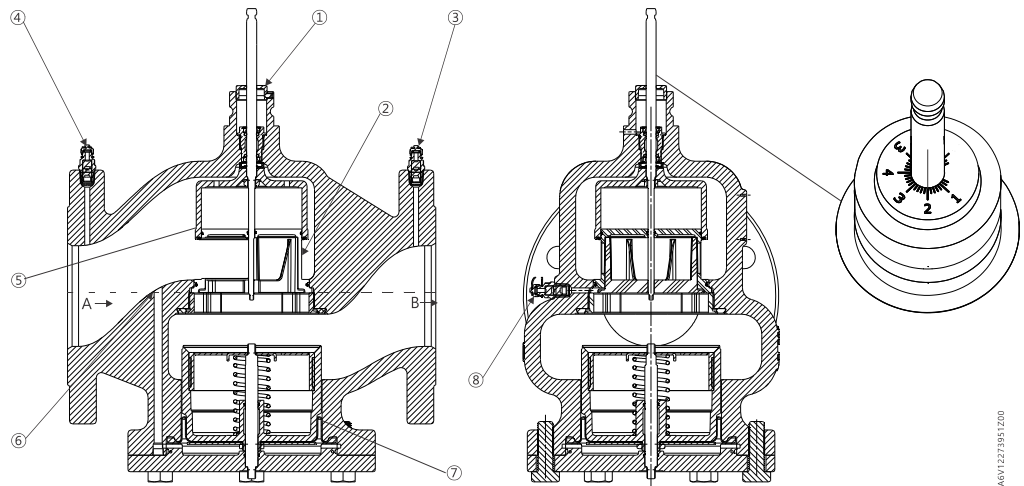

1	Ring with dial for presetting
2	Seat with variable presetting opening
3	Pressure test point (P/T) at outlet, blue ribbon, p_3
4	Pressure test point (P/T) at inlet port A, red ribbon, p_1
5	Control valve
6	Aperture for the differential pressure regulator is linked with inlet port A
7	Differential pressure controller - DPR
8	Pressure test point (P/T) at outlet of control valve, blue ribbon, p_2
A	Inlet port A
B	Outlet port B

Functional principle

The PICVs VPF43../VPF44../VPF53../VPF54.. combine three functions:

- a control valve for controlling the volumetric flow
- an adjustable mechanism with a dial for a pre-settable maximum volumetric flow
- a DPR for balancing pressure fluctuations in the hydraulic system respectively across the control valve

The mechanical series-connected differential pressure controller keeps the differential pressure ($p_1 - p_2$) constant across the control valve and thus the volumetric flow too. The desired maximum volumetric flow V_{100} can be preset with the adjusting mechanism. The controller (not shown) and the actuator regulate the volumetric flow and consequently the desired temperature in buildings, rooms or zones.

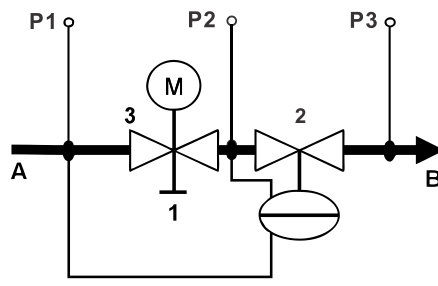

- A Inlet medium (inlet port A)
- B Outlet medium (outlet port B)
- 1 Ring with dial for presetting
- 2 Differential pressure controller (DPR)
- 3 Control valve with mounted actuator

- p_1 P/T port with red ribbon, pressure test point at inlet port A of PICV
- p_2 P/T port with blue ribbon, pressure at outlet port of control valve (3)
- p_3 P/T port with blue ribbon, pressure test point at outlet port B of PICV

Medium flow

The medium entering the PICV (inlet port A) first passes through the control valve (3) with a linear characteristic and a stroke of 20 mm (DN 50...80) respectively 40 mm (DN 100...150) and 43mm (DN 200). The actuator (not shown here) opens or closes accurately the control valve. Then, the medium flows through the variable presetting opening which is connected to the ring with dial (1) for presetting the desired maximum volumetric flow V_{100} .

Before leaving the PICV (outlet port B), the medium passes through a built-in mechanical differential pressure controller. This differential pressure controller is the heart of the PICV and ensures that the selected volumetric flow is maintained across the whole working range and independent of the inlet pressure p_1 .

Pressure test points

The PICV VPF43../VPF53.. are equipped with two pressure test points (p_1 , p_3) for measuring and monitoring the differential pressure across the valve during commissioning or operation. The PICV VPF44../VPF54.. are equipped with three pressure test points (p_1 , p_3 , p_2) for measuring and monitoring the differential pressure across the control valve and PICV during commissioning or for analysis during operation. For that purpose, the electronic manometer ALE10 can be used.

Manual control

Only possible with mounted actuator.

Advantages

The advantages of PICVs are that:

- Once the flow limiter (presetting) is set to the desired nominal flow, the hydraulic circuit is self-balanced, even when changes to the system are made, such as additions.
- For any heat or cold demand the PICV with mounted actuator can be set to the desired volumetric flow and will be relatively constant regardless of pressure fluctuations in the system.

Constant flow regardless of pressure changes in the system reduces hydraulic interdependence between hydraulic groups and leads to a more stable control.

Sizing

Engineering Example

$$\dot{V} = \frac{Q[\text{kW}] \cdot 1000}{1.163 \cdot \Delta T[\text{K}]} \left[\frac{\text{l}}{\text{h}} \right]$$

Basis of design

1. Determine heat/cold demand Q [kW]
2. Determine temperature spread ΔT [K]
3. Calculate volumetric flow
4. Select suitable PICV VPF43../VPF44../VPF53../VPF54..
5. Determine dial setting using volumetric flow/dial presetting tables, see below.

Example

1. Heat demand $Q = 150$ kW
2. Temperature spread $\Delta T = 6$ K
3. Volumetric flow

$$\dot{V} = \frac{150 \text{ kW} \cdot 1000}{1.163 \cdot 6 \text{ K}} = 21654 \text{ l/h} = 21.6 \text{ m}^3/\text{h}$$

Hint: You can also determine the volumetric flow using the valve slide rule.

4. PN class: PN16
5. Select PICV VPF44., PN16
Ideally, PICVs should be selected such that they operate at about 80 % of their maximum flow, enabling them to deliver spare capacity, if required.
Selections:
VPF44.65F25 $\Delta p_{\min} = 25$ kPa
VPF44.65F35 $\Delta p_{\min} = 40.5$ kPa
6. Determine dial setting using volumetric flow/dial presetting tables:
VPF44.65F25 Volumetric flow 21.6 m^3/h

Dial setting 3.7
 VPF44.65F35 Volumetric flow 21.6 m³/h
 Dial setting 2.5

Volumetric flow/dial presetting

Tables to determine the dial setting for a desired volumetric flow.

Δp_{min} [kPa] based on volumetric flow; interpolate missing values.

Presetting range linear to VDI/VDE 2173
Presetting range not permitted

Low flow rate

VPF44.50F15/VPF54.50F15														15 m ³ /h nominal							
\dot{v} [m ³ /h]				3.7	4.2	4.9	5.6	6.3	7.0	7.7	8.4	9.2	10.0	11.0	11.9	12.6	13.2	13.5	13.8	14.1	14.3
Dial	Min.	0.2	0.4	0.6	0.8	1	1.2	1.4	1.6	1.8	2	2.2	2.4	2.6	2.8	3	3.2	3.4	3.6	3.8	Max.
Δp_{min} [kPa]				13	14	15	16	16	17	18	18	19	20	21	21	22	23	23	24	25	25

VPF44.65F25/VPF54.65F25														25 m ³ /h nominal							
\dot{v} [m ³ /h]				4.5	5.3	6.2	7.1	7.9	8.7	9.9	11.1	12.5	13.8	15.3	16.7	17.9	19.1	20.4	21.6	23.0	24.4
Dial	Min.	0.2	0.4	0.6	0.8	1	1.2	1.4	1.6	1.8	2	2.2	2.4	2.6	2.8	3	3.2	3.4	3.6	3.8	Max.
Δp_{min} [kPa]				28	29	29	29	29	30	30	30	30	31	31	31	31	32	32	32	32	32

VPF44.80F35/VPF54.80F35														35 m ³ /h nominal							
\dot{v} [m ³ /h]				6.8	8.4	9.6	10.7	12.2	13.7	15.5	17.3	19.4	21.4	23.3	25.1	27.2	29.3	31.2	33.2	34.5	35.7
Dial	Min.	0.2	0.4	0.6	0.8	1	1.2	1.4	1.6	1.8	2	2.2	2.4	2.6	2.8	3	3.2	3.4	3.6	3.8	Max.
Δp_{min} [kPa]				18	19	19	19	19	20	20	20	20	21	21	21	21	22	22	22	22	22

VPF44.100F70/VPF54.100F70														68 m ³ /h nominal							
\dot{v} [m ³ /h]				12.2	14.8	17.3	19.8	22.5	25.2	29.1	33.0	37.1	41.2	46.2	51.1	56.3	61.5	64.3	67.2	68.4	69.6
Dial	Min.	0.2	0.4	0.6	0.8	1	1.2	1.4	1.6	1.8	2	2.2	2.4	2.6	2.8	3	3.2	3.4	3.6	3.8	Max.
Δp_{min} [kPa]				18	19	20	21	22	23	24	25	26	26	27	28	29	30	31	32	33	33

VPF43.125F110/VPF53.125F110														110 m ³ /h nominal							
\dot{v} [m ³ /h]				18.5	23	28	33	37	42	46	51	55	60	65	69	74	80	85	92	99	110
Dial	Min.	0.2	0.4	0.6	0.8	1	1.2	1.4	1.6	1.8	2	2.2	2.4	2.6	2.8	3	3.2	3.4	3.6	3.8	Max.
Δp_{min} [kPa]				16	16	16	16.4	16.8	17.2	17.6	18	18.5	19.2	19.8	20.3	21	23.3	25.3	28	30.7	35

VPF43.150F160/VPF53.150F160														160 m ³ /h nominal							
\dot{v} [m ³ /h]				25.6	31	38	44	51	57	63	72	76	82	89	96	104	111	120	128	137	148
Dial	Min.	0.2	0.4	0.6	0.8	1	1.2	1.4	1.6	1.8	2	2.2	2.4	2.6	2.8	3	3.2	3.4	3.6	3.8	Max.
Δp_{min} [kPa]				21	21	21	21.2	21.4	21.6	21.7	22	23	24.5	26.3	28	30	30.8	31.8	32.7	33.8	35

VPF43.200F210/VPF53.200F210														210 m ³ /h nominal								
\dot{v} [m ³ /h]							95	100	105	112	118	124	132	140	149	157	165	173	182	192	200	210
Dial	Min.	0.2	0.4	0.6	0.8	1	1.2	1.4	1.6	1.8	2	2.2	2.4	2.6	2.8	3	3.2	3.4	3.6	3.8	Max.	
Δp_{min} [kPa]							11	12	12	14	15	16	17	19	21	22	24	26	27	29	30	32

High flow rate

VPF44.50F25/VPF54.50F25																			25 m ³ /h nominal				
\dot{V} [m ³ /h]				5.7	6.9	7.8	8.8	9.9	11.1	12.3	13.5	15.0	16.5	18.1	19.7	21.0	22.2	22.9	23.5	24.0	24.6		
Dial	Min.	0.2	0.4	0.6	0.8	1	1.2	1.4	1.6	1.8	2	2.2	2.4	2.6	2.8	3	3.2	3.4	3.6	3.8	Max.		
Δp_{min} [kPa]				30	32	33	35	36	38	39	41	42	44	45	47	48	50	51	53	54	55		

VPF44.65F35/VPF54.65F35																			35 m ³ /h nominal				
\dot{V} [m ³ /h]				6.4	7.8	8.8	10.1	11.2	12.3	14.2	16.1	18.1	20.2	22.4	24.6	26.5	28.5	30.6	32.7	35.2	37.7		
Dial	Min.	0.2	0.4	0.6	0.8	1	1.2	1.4	1.6	1.8	2	2.2	2.4	2.6	2.8	3	3.2	3.4	3.6	3.8	Max.		
Δp_{min} [kPa]				30	32	33	34	35	36	38	39	40	41	42	43	45	46	47	48	49	50		

VPF44.80F45/VPF54.80F45																			45 m ³ /h nominal				
\dot{V} [m ³ /h]				8.5	10.5	12.2	13.9	16.0	18.0	20.2	22.4	24.7	27.0	30.2	33.4	36.5	39.6	42.5	45.4	47.2	49.0		
Dial	Min.	0.2	0.4	0.6	0.8	1	1.2	1.4	1.6	1.8	2	2.2	2.4	2.6	2.8	3	3.2	3.4	3.6	3.8	Max.		
Δp_{min} [kPa]				22	24	25	26	27	28	29	30	31	32	33	34	35	36	37	38	39	40		

VPF44.100F90/VPF54.100F90																			90 m ³ /h nominal				
\dot{V} [m ³ /h]				14.8	18.2	21.3	24.4	27.6	30.8	35.4	39.9	43.7	47.4	55.7	64.0	70.8	77.5	82.3	87.1	89.0	90.9		
Dial	Min.	0.2	0.4	0.6	0.8	1	1.2	1.4	1.6	1.8	2	2.2	2.4	2.6	2.8	3	3.2	3.4	3.6	3.8	Max.		
Δp_{min} [kPa]				20	22	23	25	26	28	29	31	32	34	35	37	38	40	41	43	44	45		

VPF43.125F135/VPF53.125F135																			135 m ³ /h nominal				
\dot{V} [m ³ /h]				23	29	36	42	48	53	59	64	70	76	81	87	93	100	107	114	122	135		
Dial	Min.	0.2	0.4	0.6	0.8	1	1.2	1.4	1.6	1.8	2	2.2	2.4	2.6	2.8	3	3.2	3.4	3.6	3.8	Max.		
Δp_{min} [kPa]				27.0	27.0	27.0	27.4	27.9	28.2	28.6	29.0	29.8	30.7	31.3	32.2	33.0	36.3	39.7	43.0	46.8	53		

VPF43.150F200/VPF53.150F200																			200 m ³ /h nominal				
\dot{V} [m ³ /h]				32	40	48	57	64	72	80	88	96	104	112	121	131	141	152	165	178	195		
Dial	Min.	0.2	0.4	0.6	0.8	1	1.2	1.4	1.6	1.8	2	2.2	2.4	2.6	2.8	3	3.2	3.4	3.6	3.8	Max.		
Δp_{min} [kPa]				33.0	33.0	33.0	33.2	33.4	33.6	33.8	34.0	36.2	38.5	40.7	43.2	46.0	49.0	52.2	56.1	60.0	65		

VPF43.200F280/VPF53.200F280																			280 m ³ /h nominal				
\dot{V} [m ³ /h]						130	137	145	153	162	170	180	189	199	209	220	232	243	256	267	280		
Dial	Min.	0.2	0.4	0.6	0.8	1	1.2	1.4	1.6	1.8	2	2.2	2.4	2.6	2.8	3	3.2	3.4	3.6	3.8	Max.		
Δp_{min} [kPa]						31	32	33	35	38	41	45	49	53	57	61	65	69	73	75	78		

Product documentation

Topic	Title	Document ID
Mounting and installation	VPF43../VPF44../ VPF53../VPF54.. Mounting instructions	A6V12190279
Product environmental compatibility	VPF44../VPF54.. The product environmental declaration A5W00159028A contains data on environmentally compatible product design and assessments (RoHS compliance, materials composition, packaging, environmental benefit, disposal).	A5W00159028A
	VPF43../VPF53.. The product environmental declaration CE1E4315en contains data on environmentally compatible product design and assessments (RoHS compliance, materials composition, packaging, environmental benefit, disposal).	CE1E4315en
EU Conformity (CE)	VPF44../ VPF54..	A5W00159722A
	VPF43../ VPF53..	CE1T4315xx

Related documents such as environmental declarations, CE declarations, etc., can be downloaded at the following Internet address:



<http://siemens.com/bt/download>

Notes

Security

	<p>⚠ CAUTION</p>
	<p>National safety regulations</p> <p>Failure to comply with national safety regulations may result in personal injury and property damage.</p> <ul style="list-style-type: none"> Observe national provisions and comply with the appropriate safety regulations.

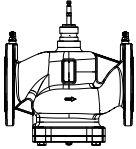
Engineering

Valve	Symbols / Direction of flow VPF44..	Flow in control mode	Valve stem	
			retracts	extends
PICV	  4315Z05	variable	Valve closes	Valve opens

	<p>⚠ WARNING</p>
	<p>The direction of flow indicated (arrow on the valve body) is mandatory!</p> <ul style="list-style-type: none"> The valves should preferably be mounted in the return pipe where temperatures are lower (for heating circuits), and where the sealing gland is less affected by strain. Valve's factory default position (without actuator) = CLOSED.

Symbol

Symbol used in catalogs and application descriptions	Symbol used in diagrams
	There are no standard symbols for PICVs in diagrams

Recommendation

- A strainer or dirt trap should be fitted upstream of the valve to enhance reliability and service life.
- Remove dirt, welding beads etc. from valves and pipes.
- Do not insulate the actuator bracket, as air circulation must be ensured!
- If flow measurement section is used (VPF44../VPF54.. only), make sure the flow measuring device is installed in a low turbulence area. In general, use the $5 \times \text{DN} / 10 \times \text{DN}$ rule, whenever possible and maintain a 10D distance from the pump.

Mounting

- PICV and actuator can easily be assembled on site. Neither special tools nor adjustments, besides flow rate presetting are required.
- The valve is supplied with Mounting Instructions A6V11464512.

Orientation

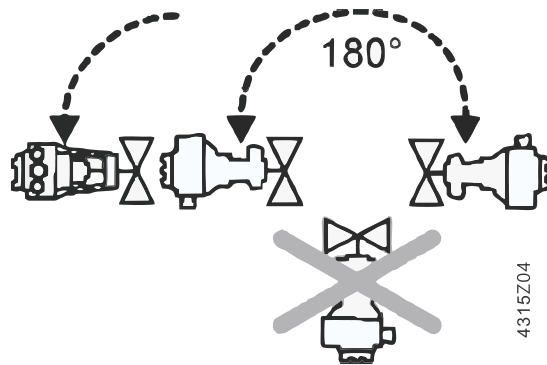

Direction flow

Pay attention to the valve's flow direction symbol during mounting.

Installation

Presetting

It is recommended to mount the actuator before the presetting is made.

1. Mount actuator and fix valve neck coupling
2. Mount valve stem coupling and tighten slightly
3. Make presetting according to table under "Volumetric flow / dia presetting". Do **NOT** adjust presetting to a dial reading lower than "0.6".
4. Tighten stem coupling

VPF43../VPF53.. ( 8 mm, \dot{V} [m³/h])

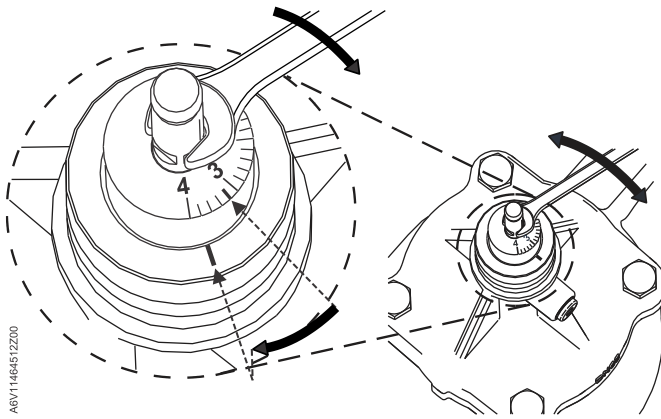

VPF44.../VPF54.. ( 8 mm, \dot{V} [m³/h])

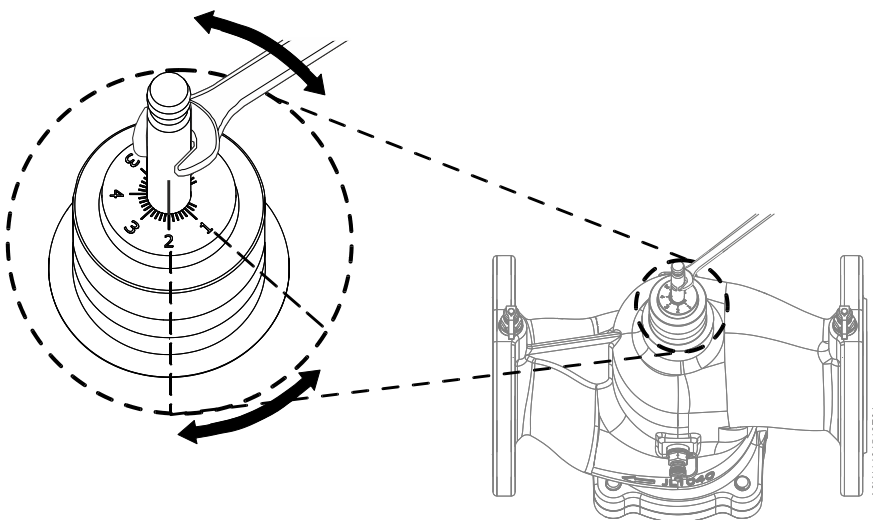

VPF44../VPF54.. has a symmetric pre-setting scale for easy commissioning. Identical pre-settings positions give identical flow rate.

Valve characteristic

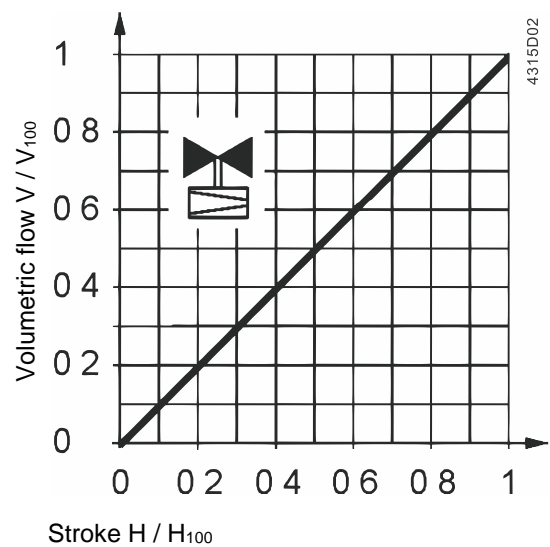

Working pressure and medium temperature

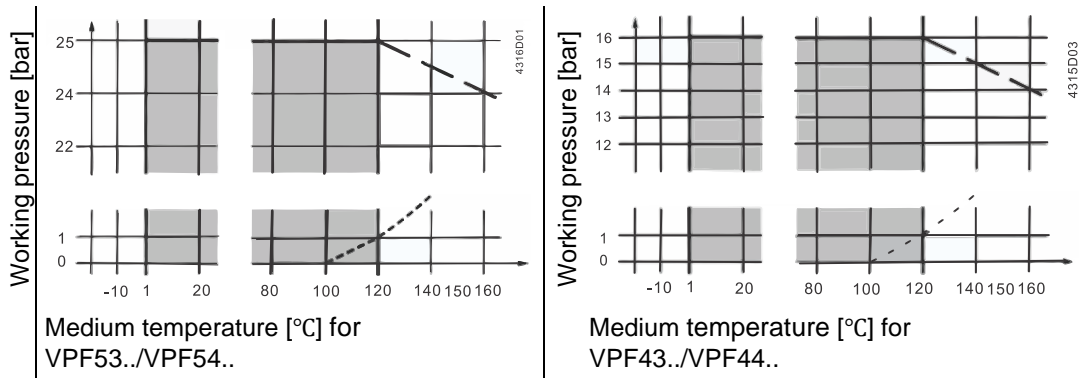

Working pressure and medium temperature staged as per ISO 7005.

	⚠ WARNING
	Current local legislation must be observed.

Commissioning

!	NOTICE
	<ul style="list-style-type: none"> • Consequences The valves must be commissioned with the actuator correctly fitted. Strong pressure impacts can damage closed PICVs. • The valves must be open when flushing or pressure testing the system. Strong pressure impacts can damage closed PICVs. • Differential pressure P_{max} across the valve's control path is not allowed to exceed 600 kPa. • Valve's factory default position (without actuator) = CLOSED.

Maintenance

All VPF... PICVs are maintenance-free. Maintenance for VPF44../VPF54.. allows easy exchange of the differential pressure controller (DPR).

	⚠ WARNING
	<p>When performing service work on the valve or actuator:</p> <ul style="list-style-type: none"> • Switch off the pump and disconnect power supply. • Close the shut-off valves in the piping network. • Fully reduce pressure in the piping network and allow the pipes to cool down completely. • Remove the electrical connections only if necessary.

Sealing gland

The stem sealing gland cannot be exchanged. In case of leakage the whole valve must be replaced.

Disposal



The valve is considered an electronic device for disposal in accordance with the European Guidelines and may not be disposed of as domestic garbage.

- Dispose of the valve through channels provided for this purpose.
- Comply with all local and currently applicable laws and regulations.

Warranty

Technical data on specific applications are valid only together with Siemens products listed under "Equipment combinations". Siemens rejects any and all warranties in the event that third-party products are used.

Technical data

Functional data			
PN class	PN16 / PN25 as per EN 1333		
Permissible operating pressure	1600 kPa (16 bar) / 2500kPa (25 bar) as per ISO 7628 / EN 1333		
Valve characteristic	Linear as per VDI / VDE 2173		
Leakage rate	Class IV (0...0.01 % of volumetric flow V_{100}) to EN 1349		
Operating direction	Normally open (push to close/pull to open)		
Permissible media	Low temperature hot water, medium temperature hot water, chilled water, water with anti-freeze Recommendation: water treatment to VDI 2035		
Medium temperature	PN16	DN 50...150: 1...120 °C DN 200: 1...110 °C	
	PN25	DN 50...125: 1...120 °C DN 150, 200: 1...110 °C	
Rangeability	1: 100		
Average flow accuracy	± 10 %	from ΔP_{min} up to 70 kPa from ΔP_{min} up to 105 kPa from ΔP_{min} up 600 kPa	(DN 50...80) (DN 100...150) (DN 200)
	± 5 %	from 70...600 kPa from 105...600 kPa	(DN 50...80) (DN 100...150)
Nominal stroke	DN 50, 65, 80: 20 mm DN 100, 125: 40 mm DN 150, 200: 43 mm		
Low-noise operation	To operate the valve at a low noise level, a differential pressure of 150 kPa should not be exceeded.		

*tested in clean water conditions, represents the maximum deviation from the average measured flow

Materials	
Valve body	DN 50...80, DN125 (PN16): Gray cast iron GJL-250 DN 50...80, DN100, 150, 200 (PN25): Nodular cast iron GJS-400-15
Stem, spring	Stainless steel
Trim	Brass (DZR)
Regulator	Stainless steel
Seals	EPDM

Norms and standards		
VPF43../VPF53.. EU Conformity (CE)	CE1T4315xx ¹⁾	
VPF44../VPF54.. EU Conformity (CE)	A5W00159722A	
EAC conformity	VPF43../VPF44../VPF53../VPF54.. Eurasia conformity	
Pressure Equipment Directive	PED 2014/68/EU	
Pressure accessories	Scope: Article 1, section 1 Definitions: Article 2, section 5	
Fluid group 2 (for VPF43../VPF53..)	DN 150 ³⁾ (PN 25) DN 200 ³⁾ (PN 16, PN 25)	Without CE-marking as per article 4, section 3 (sound engineering practice) ¹⁾
	DN 125 (PN 16, PN 25) DN 150 (PN 16)	Category I, module A, with CE-marking as per article 14, section 2
Fluid group 2 (for VPF44../VPF54..)	DN 50 (PN 16)	Without CE-marking as per article 4, section 3 (sound engineering practice) ¹⁾
	DN 65...100 (PN 16) DN 50...100 (PN 25)	Category I, module A, with CE-marking as per article 14, section 2
Environmental conformity	The product environmental declaration CE1E4315en ²⁾ (for VPF43../VPF53..), A5W00159028A ²⁾ (for VPF44../VPF54..) contain data on environmentally compatible product design and assessments (RoHS compliance, materials composition, packaging, environmental benefit, disposal).	

1). Valves where $PS \times DN < 1000$, do not require special testing and cannot carry the CE label.

2).The documents can be downloaded from <http://siemens.com/bt/download>.

3). Warm water temperature not greater than 110°C, do not require special testing and cannot carry the CE label.

General ambient conditions

Temperature	1...55 °C	-30...65 °C	-15...50 °C
Humidity	5...95 % r. h.	< 95 % r. h.	5...95 % r. h.

Dimensions/weight

Dimensions	Refer to Dimensions [on page 18]		
Weight	Refer to Dimensions [on page 18]		
Flange connections	ISO 7005-2		
Pressure test points (P / T points)	G ¼ inch (connection) 2 mm x 40 mm (measuring tips)		

Application examples

PICVs in HVAC systems combined with variable speed pumps provide even higher energy efficiency. When sizing the pump, it must be made certain that the most critical branch or consumer in the system – usually the remotest from the pump – gets enough pressure (pump head). Thus, it is recommended to use a variable speed pump in constant-pressure mode with end-point feedback, to maintain a minimum differential pressure across the critical valve.

Residential buildings

Residential buildings with for example self-contained flat heating systems:

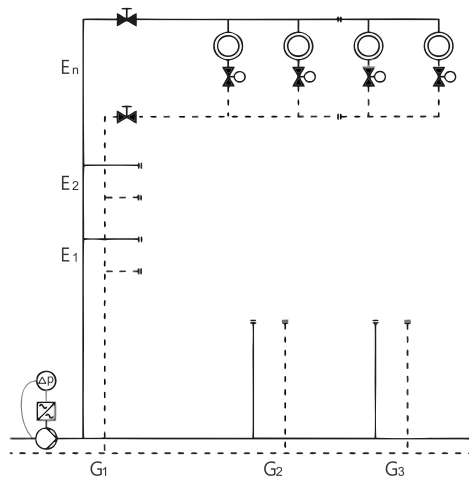

A6V11466366Z02

E = Floor
G = Group or zone
Non-residential buildings
Commercial buildings with for example Fan Coil Units or heat exchangers for heating or cooling

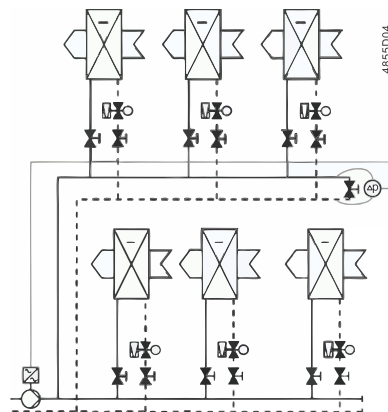

4855D04

Dimensions

Dimensions in mm: VPF44../VPF54..

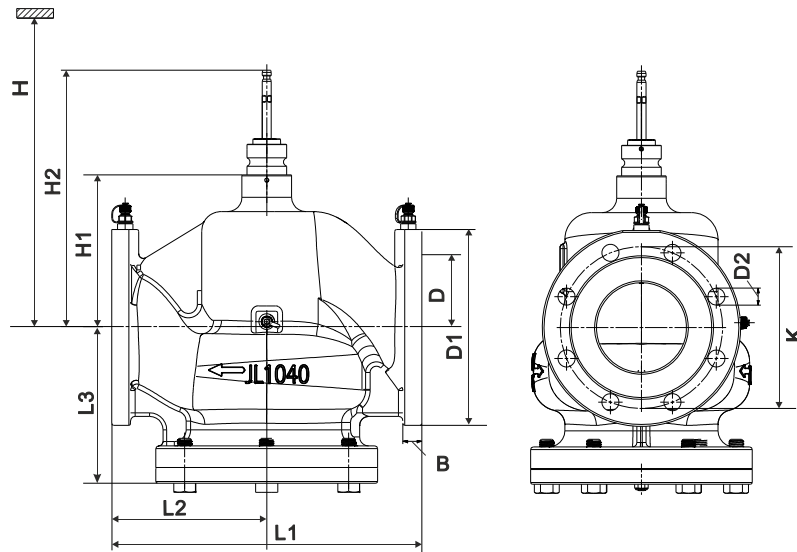

Product number	DN	B	ø D	ø D1	ø D2	L1	L2	L3	ø K	H1	H2	H			Weight
												SAX..P	SAV..P	SQV..P	
												[mm]	[mm]	[mm]	
VPF44..	50	17	165	99	19 (4x)	230	115	115	125	102.5	199	545	-	492	15
	65	17	185	118	19 (4x)	290	145	122	145	104	200.5	546	-	493	19
	80	19	200	132	19 (8x)	310	155	139	160	104.5	201	547	-	494	29
	100	21	220	156	19 (8x)	350	175	174.5	180	169	285.5	-	637	557	46
VPF54..	50	16	165	99	19 (4x)	230	115	115	125	102.5	199	545	-	492	16
	65	16	185	118	19 (8x)	290	145	122	145	104	200.5	546	-	493	20
	80	19	200	132	19 (8x)	310	155	139	160	104.5	201	547	-	494	30
	100	21	235	156	23 (8x)	350	175	174.5	190	169	285.5	-	637	557	50

Note:

DN = Nominal size

H = Total actuator height plus minimum distance to the wall or the ceiling for mounting, connection, operation, maintenance etc.

H₁ = Dimension from the pipe center to install the actuator (upper edge).

H₂ = Valve in the OPEN position means that the valve stem is fully extended.

Dimensions in mm: VPF43../VPF53..

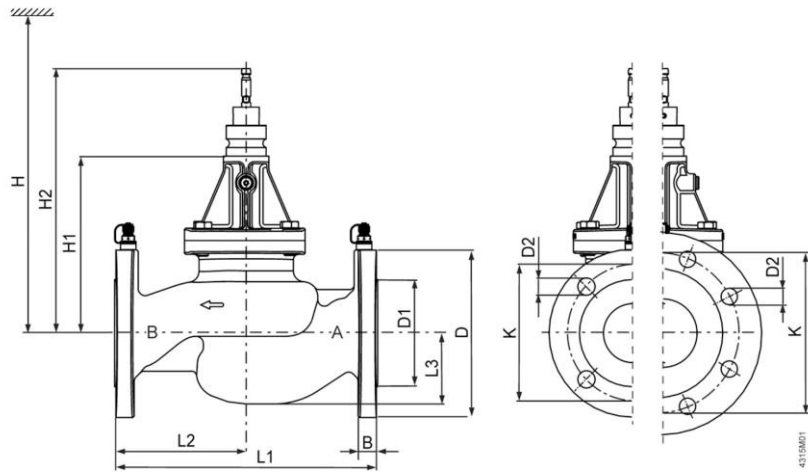

Product number	DN	B	ø D	ø D1	ø D2	L1	L2	L3	ø K	H1	H2	H			Weight
												SAX..P	SAV..P	SQV..P	
												[mm]	[mm]	[mm]	
VPF43..	125	25	270	184	19 (8x)	400	192	133	210	357	474	820	820	750	77
	150	26	285	211	23 (8x)	480	230	156	240	401	521	870	870	790	111
	200	28	380	266	23 (12x)	600	300	300	295	401	521	870	870	790	175
VPF53..	125	25	270	186	27 (8x)	400	192	134	220	357	474	820	820	750	77
	150	26	285	211	27 (8x)	480	230	156	250	401	521	870	870	790	111
	200	28	380	274	28 (12x)	600	300	300	310	401	521	870	870	790	175

Revision number overview

Product number	Valid from rev. no.	Product number	Valid from rev. no.
VPF44.50F15	..B	VPF44.50F25	..B
VPF44.65F25	..B	VPF44.65F35	..B
VPF44.80F35	..B	VPF44.80F45	..B
VPF44.100F70	..A	VPF44.100F90	..A
VPF43.125F110	..A	VPF43.125F135	..A
VPF43.150F160	..A	VPF43.150F200	..A
VPF43.200F210	..A	VPF43.200F280	..A
VPF54.50F15	..A	VPF54.50F25	..A
VPF54.65F25	..A	VPF54.65F35	..A
VPF54.80F35	..A	VPF54.80F45	..A
VPF54.100F70	..A	VPF54.100F90	..A
VPF53.125F110	..A	VPF53.125F135	..A
VPF53.150F160	..A	VPF53.150F200	..A
VPF43.200F210	..A	VPF43.200F280	..A

Documentation form

Installed location	Valve type	Actuator type	Valve size	Planned Presetting	Required Δp_{\min} [kPa]	Verified Δp_{\min} [kPa]	Flow ¹⁾²⁾ (m ³ /h)

1) Valid for VPF43../VPF44../VPF53../VPF54..: Flow = If measured Δp_{\min} (p_1-p_3) > Required Δp_{\min} (p_1-p_3), then flow is as per presetting in datasheet, otherwise check system pressure.

2) Valid for VPF44../VPF54.. only: Please refer to k_{vs} -table (provided separately).